

**GSM RECEIVER / TRANSMITTER**

ADVANCE DATA

- GSM RECEIVER/TRANSMITTER
- DIRECT CONVERSION ARCHITECTURE
- I/Q INPUTS AND OUTPUTS

**DESCRIPTION**

The STB3300 is a partially integrated GSM receiver/transmitter. The only additions required are the receiver LNA and transmitter PA. The direct conversion architecture dispenses with the need for IF transformers and the I/Q input/output structure enables direct connectivity into base band processing circuits.

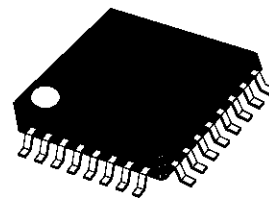

**PQFP32**  
(Plastic Quad Flat Pack)

**ORDER CODE : STB3300**

**PIN CONNECTIONS**

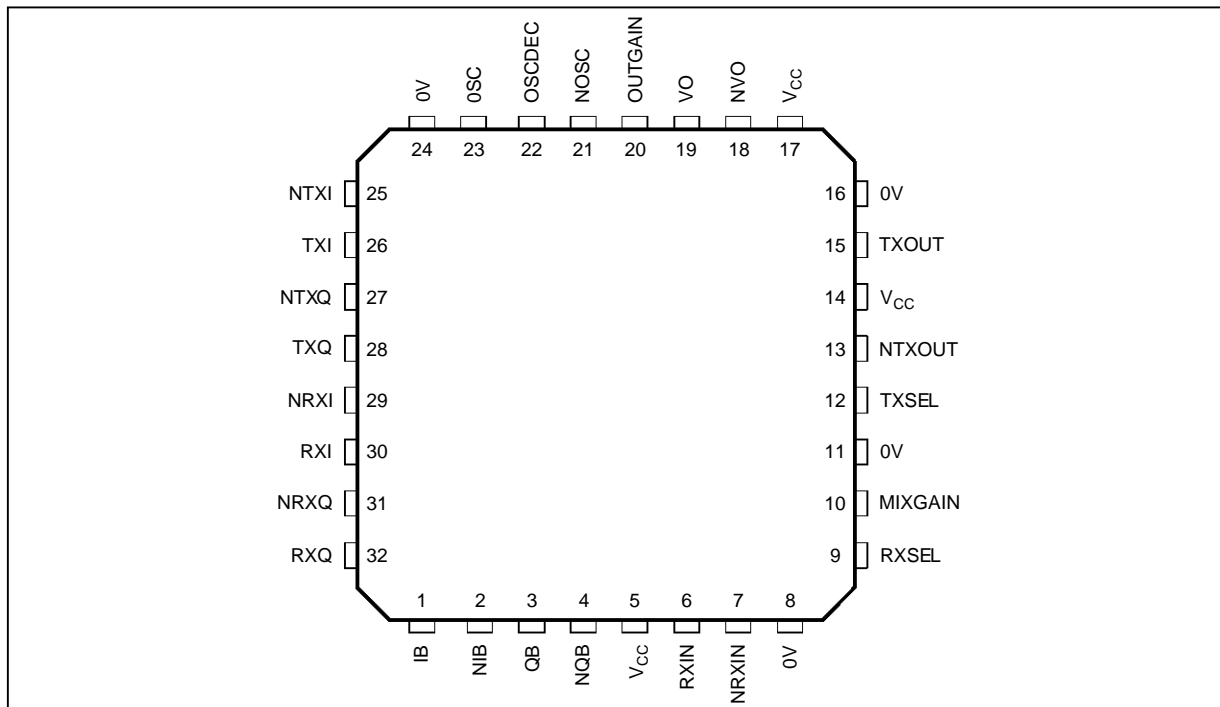

3300-01.EPS

**PIN-OUT DESCRIPTION**

Pin Number	Name	Description
1 - 2	IB - NIB	LOW PASS FILTER, I CHANNEL - RECEIVER IB is connected to NIB via a 680pF (approx.) capacitor. The capacitor value limits the signal bandwidth into the post mixer amplifiers. It is required to suppress unwanted harmonics. Note, this capacitor is used to reject high frequencies thus should be located near the IC via a low inductance path.
3 - 4	QB - NQB	LOW PASS FILTER, Q CHANNEL - RECEIVER QB is connected to NQB via a 680pF (approx.) capacitor. The capacitor value limits the signal into the post mixer amplifiers. It is required to suppress unwanted harmonics. Note, this capacitor is used to reject high frequencies thus should be located near the IC via a low inductance path.
5 - 14 - 17	V <sub>CC</sub>	+5V power supply (max. 100mA). Should be decoupled to GND by low inductance capacitors e.g. 1nF.
6 - 7	RX <sub>IN</sub> - NRX <sub>IN</sub>	MAIN Rx SIGNAL INPUT - RECEIVER The balanced receiver inputs. Designed to be self biasing and thus should be AC coupled. The NRXIN input may be AC terminated to GND via a suitable capacitor (low inductance) or may be fed via the complementary output of a 50Ω 1:1 Balun in the RXIN path. The frequency may be 925MHz to 970MHz. RF Level 0 to -80dBm. The input impedance is normally 80Ω.
8 - 11 16 - 24	0V	Low inductance path to power and RF ground.
9	RX <sub>SEL</sub>	Rx SELECT - RECEIVER Logic input. 0.5V, +4.6V. Low switches the receiver section off. High switches the receiver section on. Decoupling and ferrite beads/inductors may be used here to prevent RF propagating into the LF section . This applies to all logic inputs.
10	MIXGAIN	Rx GAIN SWITCH - RECEIVER Logic input. 0.5V, +4.6V. Switches the receiver mixer gain between high gain (4.5v) and low gain (0.5V). Low gain is 6dB lower than high gain.
12	TX <sub>SEL</sub>	Tx SELECT - TRANSMITTER Logic input. 0.5V, +4.6V. Low switches the transmitter section off. High switches the transmitter section on.
13 - 15	TX <sub>OUT</sub> - NTX <sub>OUT</sub>	Tx OUTPUT - TRANSMITTER Open collector. The TXOUT, NTXOUT signals may either be combined in a balun biased to +5V or fed individually into a +5V DC termination. The output levels are typically 0dBm. If a balun is used a 200:50Ω is normal.
18 - 19	VO - NVO	ANALOGUE INPUT - QUADRATURE GENERATOR Analogue inputs variable between 1V and +4V. Should be decoupled. The inputs are used for phase adjust, if required.
20	OUTGAIN	LOGIC INPUT - RECEIVER 0.5V, +4.6V. Switches the receiver post mixer amplifier gain between high gain (4.6V) and low gain (0.5V). Low gain is 6dB lower than high gain.
21 - 23 22	OSC - NOSC OSC DEC	OSCILATOR INPUT - VCO The balanced local oscillator inputs. These inputs are designed to be driven by an RF balun biased from Pin 22 (OSCDEC). If a balun is used a 200:50Ω is Normal. RF level 0.2V <sub>RMS</sub> .
25 - 26	NTXI - TXI	Tx INPUT, I CHANNEL - TRANSMITTER The balanced LF I phase for the transmitter quadrature mixer. The nominal operating bandwidth is about 100kHz. The two inputs may be driven independently but must 180 Degrees out of phase with each other. The inputs are high impedance. The required DC voltage is V <sub>supply</sub> /2 i.e. 2.5V static DC. The AC voltage is 250mV per phase or greater.
27 - 28	NTXQ - TXQ	Tx INPUT, Q CHANNEL - TRANSMITTER The balanced LF Q phase for the transmitter quadrature mixer. The signal requirements are exactly the same as for the I phase (Pins 25 and 26) but TXQ is 90 Degrees out of phase with respect to TXI.
29 - 30 31 - 32	RXI - NRXI RXQ - NRXQ	Rx I/Q OUTPUTS - RECEIVER The receiver base band output. The signal bandwidth is from DC to approximately 1MHz.

3300-01.TEL

**BLOCK DIAGRAM**

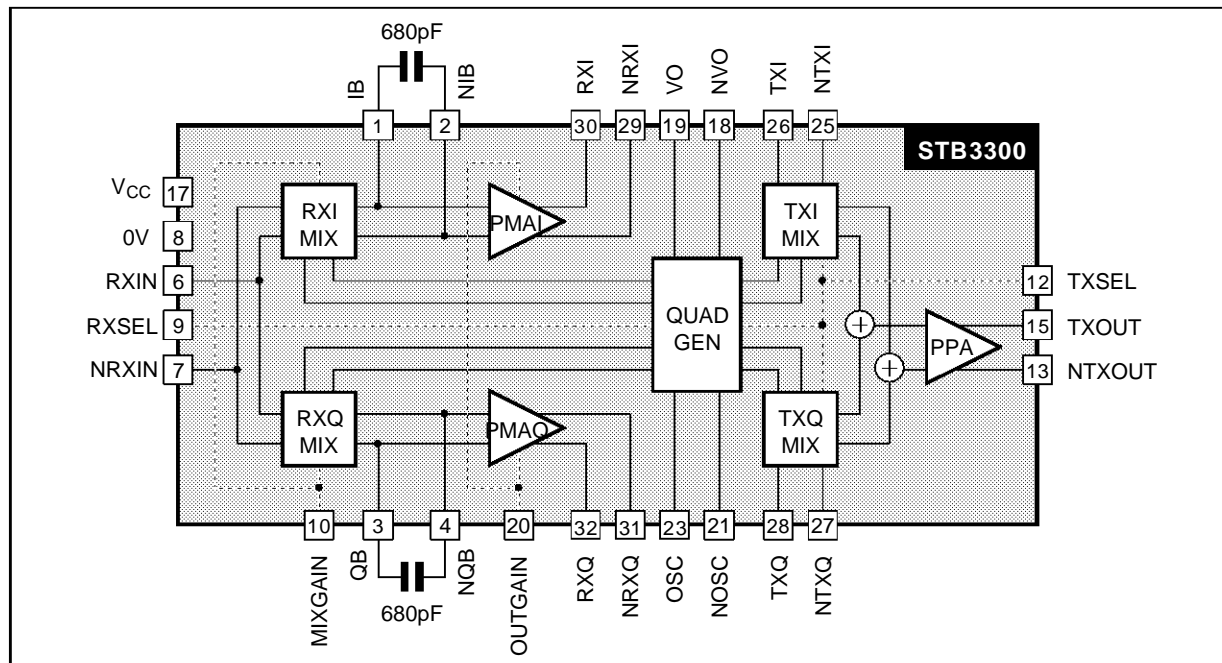

3300-02.EPS

**EXTERNAL COMPONENTS REQUIREMENTS**

Description	Value	Unit
Decoupling for Vcc Lines	27 1	pF nF
Pre-blocking Filter Capacitors (A)	680	pF
Decoupling for OUTGAIN	27	pF
Decoupling for MIXGAIN	27	pF
Decoupling for TXSEL	27	pF
Decoupling for RXSEL	27	pF
Decoupling for NRXIN (if no input Balun is used)	30	pF

3300-10.TBL

**FUNCTIONAL DESCRIPTION**

The STB3300 comprises of a quadrature modulator and quadrature demodulator. The transmitter is of the direct up conversion type. The receiver is of the direct down conversion type. Thus there is no I.F (Please refer to the block diagram).

On the receiver side RXIN/NRXIN provide the balanced input from the aerial/LNA combination. OSC and NOSC provide the local oscillator inputs. The control over the receiver is effected by the control lines MIXGAIN and OUTGAIN. MIXGAIN controls the gain of the input mixer stage. OUTGAIN controls the gain of the post mixer (or baseband) amplifiers. These two controls are logical i.e. either high or low providing a fixed change in gain. Nominally 6dB each for both the mixer and the post amplifier i.e. 12dB total gain change. The maximum gain of the receiver section is about 20dB.

RXI/NRXI and RXQ/NRXQ are the receiver output. The output frequency is base band i.e. less than 300kHz (with the 680pF capacitor inserted). A further logic signal RXSEL switches on (off) the receiver section of the IC.

For the transmit side the local oscillator inputs are provided via OSC and NOSC (as for the receiver). The I and Q inputs are provided by TXI/NTXI and TXQ/NTXQ. Nominally the I and Q inputs are 90 degrees phase shifted with respect to each other they have approximately the same amplitude. Their frequency is again baseband from 0 to 300kHz. The control signal TXSEL switches on (off) the transmitter section of the IC.

The analogue inputs VO and NVO control the relative phase offsets between the internally generated I and Q local oscillator signals.

## STB3300

---

### ABSOLUTE MAXIMUM RATINGS

Symbol	Parameter	Value	Unit
$V_{CC}$	Power Supply Voltage	5.25	V
$V_I, V_O$	Voltage on Inputs	-0.5, +7	V
$T_{stg}$	Storage Temperature	-25, +80	oC
$T_{oper}$	Operating Temperature	-40, +125	oC

3300-02.TBL

### ELECTRICAL CHARACTERISTICS

Symbol	Parameter	Min.	Typ.	Max.	Unit
$V_{CC}$	Supply Voltage	4.75		5.25	V
$I_{CC}$	Supply Current : - Rx mode, maximum gain - Rx mode, -6dB relative gain - Rx mode, -12dB relative gain - Tx mode - Quiescent (sleeping) mode		27 19 15 1	35 25 20 60 20	mA mA mA mA $\mu$ A

3300-03.TBL

### TURN ON/OFF TIMES

Symbol	Parameter	Min.	Typ.	Max.	Unit
$t_{ON}$	Turn-on Time (power) Sleep to Rx or Sleep to Tx			5	$\mu$ s
$t_{OFF}$	Turn-off Time (power) Rx to sleep or Tx to Sleep			5	$\mu$ s
$Q_C$	Supplementary turn on/off charge for External Capacitor			200	nC

3300-04.TBL

## RECEIVER SECTION

Symbol	Parameter	Min.	Typ.	Max.	Unit
SIGNAL INPUTS					
$f_{OP\ RX}$	Frequency Range	925		970	MHz
$\Delta P_{SC\ RX}$	Signal Compression (at Maximum Gain) of the wanted signal in the presence of a compression blocking level		-6	2	dB dBm
$f_{B\ RX}$	Blocking Signal		3		MHz
$P_{INP3\ RX}$	Input IP3 at Maximum Gain	0			dBm
$N_{RX}$	Noise Figure - Signal Uncompressed (see Note 1) a) At Maximum Gain Setting b) At -6dB Relative Gain Setting c) At -12dB Relative Gain Setting		17 21 22		dB
$N_{RX}$	Noise Figure at -6dBm Blocking Signal at Chip Input (Noiseless Oscillator) (see Note 2) Blocking signal distance from carrier a) Maximum gain setting b) -6dB relative gain c) -12dB relative gain		3 21 24 25		MHz dB dB dB
$Z_{IN\ RX}$	Input Impedance	64		96	$\Omega$
$P_{LO\ LK}$	Balanced Local Oscillator Leakage to Input (Referenced to 50 $\Omega$ )			-45	dBm
$PSRR_{RX}$	Power Supply Rejection Ratio in the Frequency Bands DC to $f_c$ - 200kHz $f_c$ to $f_c$ + 200kHz - $V_{CC}$ and SELECT Pins - Ground Pins			-40 -45	dB
$I_{SEL\ RX}$ $I_{SEL\ TX}$	Rx Switch Input Currents (RXSEL, MIXGAIN, OUTGAIN) - Receive Mode - Transmit Mode or Quiescent			1 1	mA $\mu$ A
	Receiver Input Ports	RXIN and NRXIN Balanced Input Pins			
	Receiver and Transmitter Select Conditions (see Table 1)				
$V_{SEL\ ON\ RX}$	Turn-on Voltage Requirement for MIXGAIN, OUTGAIN, RXSEL or TXSEL	$V_{CC}$ - 0.15		$V_{CC}$	V
$V_{SEL\ OFF\ TX}$	Turn-off Voltage Requirement for MIXGAIN, OUTGAIN, RXSEL or TXSEL	GND + 0.15		GND	V
$P_{IN\ MAX\ RX}$	Maximum In-band Input Signal (see Note 3) a) Maximum Gain Setting b) -6dB Gain Setting c) -12dB Gain Setting			-16 -10 -6	dBm

- Notes :** 1. Noise figures are measured in a 100kHz baseband at the chip output. Reference noise is unfiltered input from a 50 $\Omega$  source.  
2. These figures require that the quadrature generation produces noise, at maximum gain, below 146dBc/Hz.  
3. I and Q differential output levels may be up to 1.0V<sub>RMS</sub> at these levels. Clipping of peaks could occur at a 0.71V<sub>RMS</sub> differential output level. (Referenced to 80 $\Omega$ ).

Table 1 : Receiver Transmitter Select Conditions

Mode	Gain Conditions	Select Pins			
		RXSEL	MIXGAIN	OUTGAIN	TXSEL
Rx Mode	Maximum Gain	H	H	H	L
	-6dB Relative Gain	H	L	H	L
	-12dB Relative Gain	H	L	L	L
Tx Mode		L	L	L	H
Quiescent		L	L	L	L

# STB3300

## RECEIVER SECTION (continued)

Symbol	Parameter	Min.	Typ.	Max.	Unit
GAIN					
$A_{V\text{ RX}}$	Differential Voltage Conversion Gain at maximum gain setting O/P open circuit measured from a 50Ω generator on the 80Ω Zin, this corresponds to voltage gain	20.5	23	25.5	dB
$A_{V\text{B RX}}$	Differential Voltage Conversion Gain at maximum gain setting in presence of a -6dB blocking signal at 1.6MHz from the carrier	21			dB
$\Delta A_{\text{RX}}$	Gain Variation With Frequency With Temperature With Supply With Process 100μs to 700μs after Turn-on			0.4 0.5 0.1 1.5 0.04	dB
$CS_{\text{LO H2 RX}}$ $CS_{\text{LO H3 RX}}$	Conversion Suppression at LO Harmonics Harmonic 2 Harmonic 3			-25 -23	dB
$\Delta A_{\text{CONT}}$	Gain Control - Conversion Gain Change Accuracy -6dB versus Maximum Gain Setting Change with Process Change with Frequency Change with Temperature Change with Supply			±0.8 ±0.4 ±0.1 ±0.2 ±0.1	dB dB dB dB
$\Delta A_{\text{CONT}}$	Gain Control - Conversion Gain Change Accuracy -12dB versus -6dB Setting Change with Process Change with Frequency Change with Temperature Change with Supply			±0.5 ±0.2 ±0.1 ±0.1 ±0.1	dB dB dB dB

## I AND Q OUTPUTS

$f_{\text{BASE RX}}$	Baseband Frequency	DC		240	kHz
$f_{\text{BASE 3dB RX}}$	Pre-blocking Filter (A) 3dB Roll Off (requires external capacitors ±5% tolerance to archive range)	240		360	kHz
$T_{\text{G DEL RX}}$	Group Delay Distorsion in 0 - 100kHz (calculated from group delay of a RC filter)			0.1	μs
$\Delta T_{\text{G DEL RX}}$	Group Delay Mismatch between Channel (this requires that the external filter capacitors are matched at worst 4%)			40	ns
$Z_{\text{OUT RX}}$	Differential Output Impedance	1600		2400	Ω
$\Delta A$	Gain Mismatch (I-NI) to (Q-NQ) Change in Above with AGC Change in Above with Temperature I to NI or Q to NQ			±0.5 ±0.4 ±0.1 ±0.2	dB
$f_{\text{BL 3dB RX}}$	Pre-blocking Filter (B) 3dB Roll Off	1.6		2.4	MHz
$\Delta \Phi_{\text{RX}}$	Phase Mismatch I to NI or Q to NQ (I-NI) to (Q-NQ) for perfectly generated phase quadrature signals Quadrature Generation Accuracy (I-NI) to (Q-NQ) for Perfectly Generated Phase Signal with Temperature (see Section below) (I-NI) to (Q-NQ) for Perfectly Generated Phase Signal with Frequency			±0.5 ±1.5 ±0.3 ±0.05	Deg
$V_{\text{OFF RX}}$	Offset Voltage Total Maximum Offset (I-NI) or (Q-NQ) Drift of "total maximum offset (I-NI) or (Q-NQ)" between 100μs and 700μs after power-up			±40 ±30	mV μV
$V_{\text{OUT DC RX}}$	DC Level (I+N)/2 or (Q+NQ)/2	$V_{\text{CC}}$ - 2.25		$V_{\text{CC}}$ - 2.75	V
$\Delta V_{\text{OUT RX}}$	I and Q Output Swing Differential Open Circuit Load			2	$V_{\text{PP}}$

3300-07.TBL

## QUADRATURE GENERATION SECTION

Symbol	Parameter	Min.	Typ.	Max.	Unit
$\Delta\Phi_{\text{QUAD}}$	Phase Mismatch (Excluding Effects Defined in Before) (RFI-NRFI) to (RFQ-NRFQ) As Above, with Sinusoidal Oscillator (RFI-NRFI) to (RFQ-NRFQ) with Temperature As Above, with Sinusoidal Oscillator and Temperature RFI-NRFI) to (RFQ-NRFQ) with Frequency As Above, with Sinusoidal Oscillator and Frequency (RFI-NRFI) to (RFQ-NRFQ) with Gain Control As Above, with Sinusoidal Oscillator and Gain Control (RFI-NRFI) to (RFQ-NRFQ) with Supply As Above, with Sinusoidal Oscillator and Supply			$\pm 3.5$ $\pm 3.0$ $\pm 0.8$ $\pm 0.6$ $\pm 0.6$ $\pm 0.3$ $\pm 1.0$ $\pm 0.7$ $\pm 0.5$ $\pm 0.5$	Deg. Deg. Deg. Deg. Deg. Deg. Deg. Deg. Deg. Deg.
$\Phi_{\text{ADJ QUAD}}$	Phase Adjustment : (VO + NO)/2 ( $\pm 8\%$ ) (VO-NVO) Range for Full Adjustment (RFI-NRFI) to (RFQ-NRFQ) Phase Adjustment Range Phase Adjustment Input Impedance	- 0.5	$V_{\text{CC}}/2$	+ 0.5 + 6 10	V V Deg. k $\Omega$
$N\Phi_{\text{QUAD}}$	Phase Noise on (RFI-NRFI), (RFQ-NRFQ) for Noiseless Input, Single Sideband at $f_{\text{c}} > 600\text{kHz}$			-147	dBc/Hz
$V_{\text{OSC QUAD}}$	Oscillator Waveform Oscillator Signal level (OSC-NOSC) 2nd Harmonic Content 3rd Harmonic Content Higher Harmonics DC Level (OSC+NOSC)/2 (= OSCDEC) DC Offset OSC to NOSC Amplitude Mismatch OSC to NOSC Phase Mismatch	0.15	3.6	0.20 -54 -30 -55 10 1 10	$V_{\text{RMS}}$ dBc dBc dBc V mV dB Deg.
$Z_{\text{IN QUAD}}$	Differential OSC/NOSC Input Impedance over the LO Band		120		$\Omega$
$V_{\text{LO QUAD}}$	RFI and RFQ Quadrature LO Signals RFI and RFQ Drive Level to the Rx and Tx Mixers	0.1480		0.1520	$V_{\text{RMS}}$

3300-08.TBL

# STB3300

## TRANSMITTER SECTION

Symbol	Parameter	Min.	Typ.	Max.	Unit
--------	-----------	------	------	------	------

### RF OUTPUT

$f_{OP\ TX}$	Frequency	890		915	MHz
$P_{OUT\ TX}$	Open Collector Output Level into 200 $\Omega$ (Line-Line) balanced load	0	3		dBm
$V_{SWR\ TX}$	Output VSWR Open Collector Output to be terminated on a 200W $\pm$ 10% balanced load			3:1	
H2 H3	Hamonic Content 2nd Harmonic 3rd Harmonic			-30 -12	dBs
$N_{OUT\ TX}$	Output Noise Output Noise $f-f_c > 600kHz$ S/N Ratio Measured over the Band $f_c$ to $f_c \pm 600kHz$	60		-147	dBs/Hz dB
$\Phi_{TX}$	Stage Contribution to Phase Mismatch			$\pm 1.0$	Deg.
	Image Rejection - Ideal I and Q Phase : Phase Accuracy Requirement for 369dB Image Rejection	40		$\pm 1.4$	dB Deg.
$C_{STX}$	Carrier Suppression	36			dBs
$IP_{2TX}$	2nd Order Distorsion			-42	dBs
$IP_{3TX}$	3rd Order Distorsion			-42	dBs
$GDD_{TX}$	Group Delay Distorsion (0 - 100kHz)			0.1	$\mu$ sec
$\Delta T_{GDD\ TX}$	Group Delay Mismatch			40	nsec
$\Delta P_{TX\ OP}$	In Band Ripple			$\pm 0.2$	dB

### ANALOGUE I AND Q INPUTS

$f_{IN\ TX}$	Frequency			100	kHz
$V_{IN\ TX}$	(I-NI)/2 , (Q-NQ)/2		$V_{CC}/2$ $\pm 5\%$		V
$Z_{IN\ TX}$	Differential Input Impedance	50			k $\Omega$
$V_{IN\ MAX\ TX}$	(I-NI), (Q-NQ) Signal Voltage Maximum Level		$1 \pm 0.2dB$		$V_{PP}$
$PSRR_{TX}$	Power Supply Rejection Ratio in the Frequency Bands DC to 200kHz, $f_c$ to $f_c \pm 200kHz$ $V_{CC}$ and Select Pins			-40	dB
$Z_{IN\ TX}$	Differential Source Impedance (I to NI) or (Q to NQ) for Achievement of -147dBs/Hz Noise Floor (at $f-f_c > 400kHz$ )			800	$\Omega$
$V_{SEL\ TX}$ $V_{SEL\ RX}$	Control Signal (TXSEL) Input Current Tx Mode Rx Mode and Power Down Mode			0.5 1	mA $\mu$ A

3300-09.TBL



APPLICATION TEST SCHEMATIC

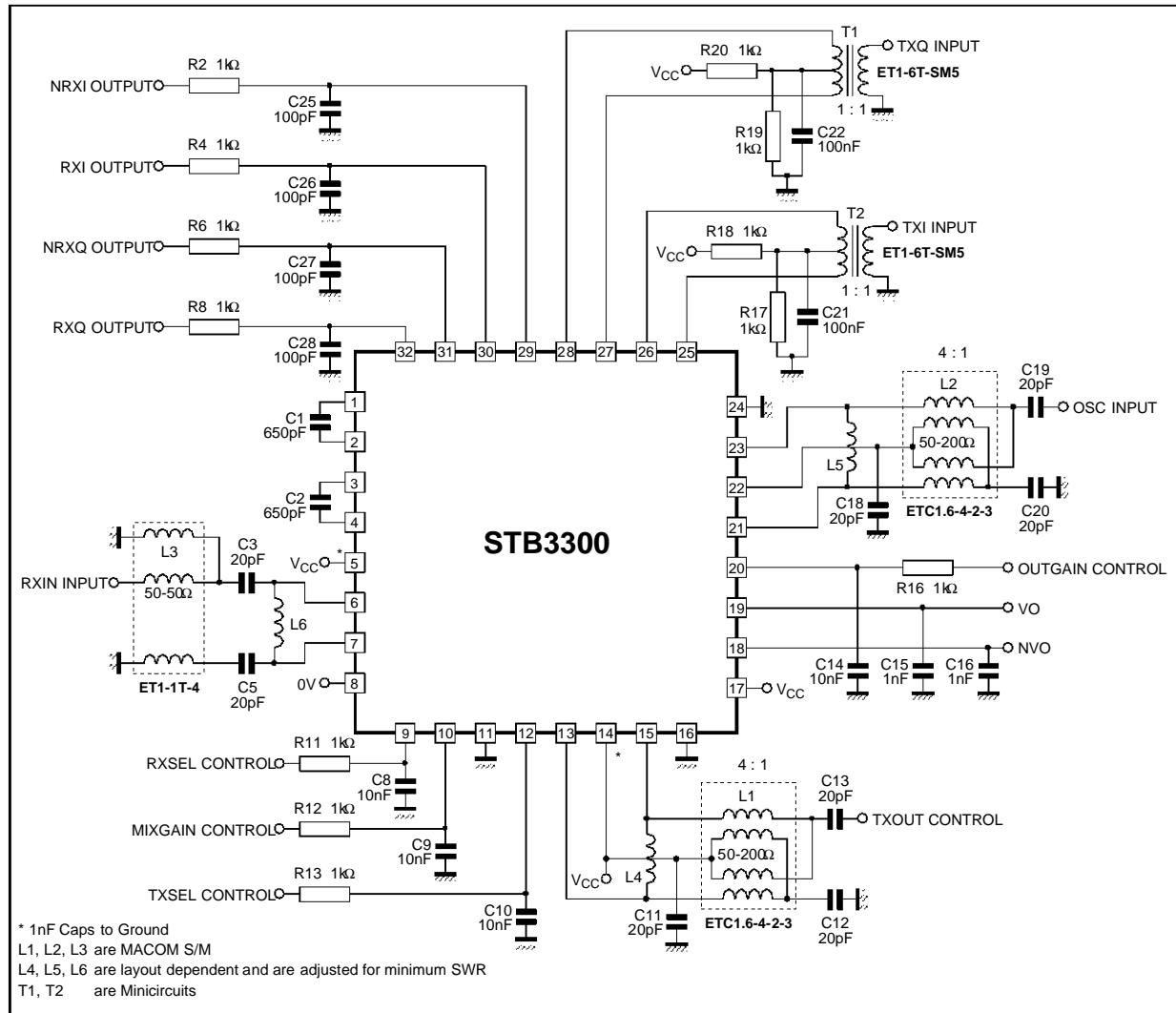

3300-03.EPS

**PACKAGE MECHANICAL DATA**  
**32 PINS - PLASTIC QUAD FLAT PACK**

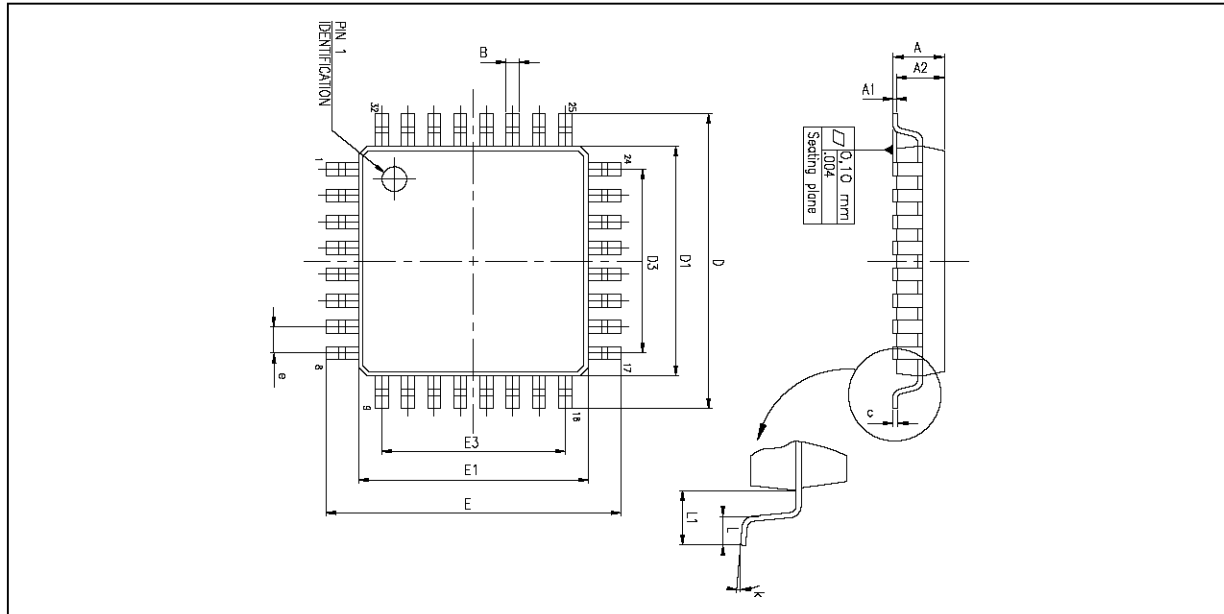

PMQFP32.EPS

Dimensions	Millimeters			Inches		
	Min.	Typ.	Max.	Min.	Typ.	Max.
A			1.60			0.063
A1	0.05		0.15	0.002		0.006
A2	1.35	1.40	1.45	0.053	0.055	0.057
B	0.30	0.37	0.45	0.012	0.0145	0.0177
C	0.09		0.20	0.004		0.0078
D		9.00			0.354	
D1		7.00			0.276	
D3		5.60			0.220	
e		0.80			0.0314	
E		9.00			0.354	
E1		7.00			0.276	
E3		5.60			0.220	
L	0.45	0.60	0.75	0.177	0.024	0.028
L1		1.00			0.039	
K	0° (min.), 7° (max.)					

POFP32.TBL

Information furnished is believed to be accurate and reliable. However, SGS-THOMSON Microelectronics assumes no responsibility for the consequences of use of such information nor for any infringement of patents or other rights of third parties which may result from its use. No licence is granted by implication or otherwise under any patent or patent rights of SGS-THOMSON Microelectronics. Specifications mentioned in this publication are subject to change without notice. This publication supersedes and replaces all information previously supplied. SGS-THOMSON Microelectronics products are not authorized for use as critical components in life support devices or systems without express written approval of SGS-THOMSON Microelectronics.

© 1994 SGS-THOMSON Microelectronics - All Rights Reserved

Purchase of I<sup>2</sup>C Components of SGS-THOMSON Microelectronics, conveys a license under the Philips I<sup>2</sup>C Patent. Rights to use these components in a I<sup>2</sup>C system, is granted provided that the system conforms to the I<sup>2</sup>C Standard Specifications as defined by Philips.

SGS-THOMSON Microelectronics GROUP OF COMPANIES

Australia - Brazil - China - France - Germany - Hong Kong - Italy - Japan - Korea - Malaysia - Malta - Morocco  
 The Netherlands - Singapore - Spain - Sweden - Switzerland - Taiwan - Thailand - United Kingdom - U.S.A.